

SEWING FOCUS

TECHNICAL SEWING INFORMATION

SERVICEHOUSE



Workwear

Checklist for Sewing Workwear

Sewing Parameters: SCHMETZ Tip:

Needle size	NM	SIZE
	60 – 120	8 – 19
	Depending on the thickness of the material. We recommend the use of the SCHMETZ SERV 7 needle.	

Needle point In the production of workwear, mostly round points and ball points are used.

Sewing thread Mainly 100 % polyester/polyester or polyester/cotton core spun threads are used.

Machine Industrial high-speed sewing machines with stitch types 301 (double lockstitch) and 401 (double chain stitch) are very common. But also automatic programmable sewing units are utilized.

Other factors:

Thread tension The necessary thread tension depends on fabric, sewing thread and sewing machine. Thread tension should be kept as low as possible in order to ensure an even and good stitch appearance.

Stitch type Double lockstitch (stitch type 301), double chain stitch (stitch type 401) and certain types of overedge chain stitch (class 500); all stitch types according to DIN 61400.

Stitch density Stitch density should be coordinated with material composition, number of layers and the desired seam strength or seam elasticity.
But: no more than 4 – 5 stitches/cm.

Quick Reference for Typical Sewing Problems in Workwear Manufacturing





Symptoms	Effect	Cause
----------	--------	-------

Skip stitches/Thread breakage

No interlacing/interlooping of needle thread and bobbin/looper thread	Reduced seam strength, especially with double chain stitch	Incorrect thread tension
Needle thread breaks	Sub-standard, defective seam appearance	Incorrect needle system
Ravelling of the needle thread	Opening of the whole seam especially with double chain stitch	Needle incorrectly fitted
	Thread breakage after skip stitch	Adhesion of melted residues, clogging of the needle eye and needle groove
	Jamming of the sewing thread due to stitch holes which are clogged	Use of an oversized sewing thread in relation to the needle size
	Partly or whole melting through of the needle thread	Needle deflection due to extremely thick layers of material at cross seams
		Oversized aperture of throat plate, material is pulled into it and prevents the loop formation
		Undersized aperture of the throat plate, material is jammed
		Overheating of sewing machine needle
		Mechanical damage to needle, throat plate, feed etc.
		“Tipping over” of the needle thread loop
		Arching up of the material due to insufficient presser foot pressure
		Jamming of the sewing thread between needle and fabric
		Incorrect thread guidance

Uneven seam appearance

Stitch sequence is irregular, resulting in a zig-zagging seam	Reduced seam strength	Incorrect adjustment of the sewing accessories such as hook/looper, feed etc.
	Sub-standard, defective seam appearance	Incorrect balance of thread tension
		Incorrect thread guidance
		Needle deflection too heavy
		Damaged thread guiding elements

Solution			
NM SIZE	Point style	Thread	Machine
			

<p>Use the SCHMETZ SERV 7 needle</p> <p>Adjust needle size to the material and amount of layers and thread size</p> <p>Change needle regularly (after every shift or after a shorter interval depending on the stress)</p> <p>BLUKOLD needle with Teflon coating. This needle coating prevents or greatly reduces the adhesion of melted residues</p> <p>CAUTION: Use of the BLUKOLD needle does not reduce the needle temperature which is caused by excessive sewing speed</p> <p>Check needle eye and groove for damage, if in doubt: change needle</p>	<p>Check point for damage</p>	<p>Adjust sewing thread size to the needle size</p> <p>Optimize thread tension</p> <p>Use core-spun threads as bobbin/looper threads</p>	<p>Optimize the hook/looper setting</p> <p>Examine the thread guiding elements</p> <p>Adjust the sewing accessories such as throat plate, feed etc. depending on material thickness and sewing thread/needle</p> <p>Reduce sewing speed</p> <p>Change worn out or defective sewing accessories regularly, such as thread guiding elements, hook/looper, throat plate etc.</p> <p>Use the right presser foot and the right adjustment of the presser foot pressure</p> <p>Check throat plate for damage</p>
---	-------------------------------	--	--

<p>Use the SCHMETZ SERV 7 needle</p> <p>Adjust needle size to the material and amount of layers</p>	<p>R Normal round point</p> <p>SES Light ball point</p> <p>SUK Medium ball point</p>	<p>Optimize thread tension</p> <p>Check thread flow</p> <p>Choose the right sewing thread size according to the needle size and the fabric</p>	<p>Examine the thread guiding elements</p> <p>Check and adjust the material transport</p>
---	--	--	---

Quick Reference for Typical Sewing Problems in Workwear Manufacturing

Symptoms	Effect	Cause
----------	--------	-------

Fabric damage

Damage to fabric	Reduced tensile strength of the material	Needle size too big and/or wrong point style
Stitch holes with melted residue of fabric threads	Sub-standard, defective seam appearance	Excessive sewing speed
Mesh damage	Reduced seam strength	Defective/worn out needles
Pulled out weft and warp threads		Unsuitable finish
Stitch holes visible, weft or warp threads destroyed		Oversized aperture of throat plate, material is pulled into it and gets damaged
		Undersized aperture of the throat plate, material is jammed
		Damaged sewing accessories such as throat plate, feed etc.

Seam puckering

Formation of undesirable waves along the seam	Shifting of material layers	Incorrect adjustment of the sewing accessories such as hook/looper, feed etc.
	Reduced seam strength	Incorrect balance of thread tension
		Incorrect thread guidance
		Wrong sewing accessories: too rough toothed feed, too large aperture of the throat plate, wrong feed
		Oversized needle
		Stitch density too high
		Presser foot pressure too high
		Selection of unsuitable stitch type
		Use of an oversized sewing thread and/or wrong sewing thread

Solution

NM SIZE



Point style



Thread



Machine

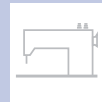

Use the SCHMETZ SERV 7 needle
Adjust needle size to the material and amount of layers

R
Normal round point

SES
Light ball point

Check point for damage

CAUTION: It is advisable to change the needle after every shift or after a shorter interval depending on the stress

Choose the right sewing thread size according to the needle size and the fabric

Adjust the sewing accessories such as throat plate, feed etc. depending on material thickness and sewing thread/needle

Check and adjust the material transport

Use of thinner needles

Adjust needle size to the material and amount of layers

R
Normal round point

SPI
Acute round point

Optimize thread tension

Choose the right sewing thread size according to the needle size and the fabric

Optimize stitch density

Use core-spun threads

Use of special feeds (roller or teflon foot)

Use of special sewing accessories

Use of fine-toothed feed

Correct thread guidance

Adjust the sewing accessories such as throat plate, feed etc. depending on material thickness and sewing thread/needle





Adjust presser foot pressure

Check stitch type and stitch density.
We recommend: 4 – 6 stitches/cm

Select stitch types with more elasticity: zig-zag stitch, double chain stitch, overedge and covering chain stitch

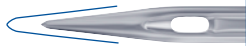
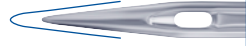
Examine the thread guiding elements

Selection of Point Style and Needle Size

Material	Number of layers	Needle size NM / SIZE	Point style
Light fabrics	2 – 4	60 – 70 / 8 – 10	R normal round point 
	6 – 10	80 – 100 / 12 – 16	
Medium fabrics	2 – 4	80 – 90 / 12 – 14	SES light ball point 
	6 – 10	100 – 120 / 16 – 19	
Heavy fabrics	2 – 4	90 – 110 / 14 – 18	SES light ball point 
	6 – 10	110 – 120 / 18 – 19	SUK medium ball point 
Disposable clothing		60 – 70 / 8 – 10	R normal round point 
			SPI acute round point 

General recommendation in manufacturing workwear:
Use of the SERV 7 needle version with the appropriate point style



Contents

1. Manufacturing of workwear
 - 1.1 Typical sewing problems
 - 1.2 Quality seams with the right sewing parameters
2. Selection of the right needle
 - 2.1 Needle size
 - 2.2 Point style
 - 2.3 SERV 7 needle construction
 - 2.4 BLUKOLD needle
 - 2.5 Changing of the needle
3. Selection of sewing thread and stitch parameters
 - 3.1 Composition and size of the sewing thread
 - 3.2 Stitch type
 - 3.3 Stitch density
 - 3.4 Thread tension
4. Sewing machines for the manufacturing of workwear
 - 4.1 Feed
 - 4.2 Throat plate/Throat plate aperture size
 - 4.3 Sewing speed
5. Our advice
6. SERVICEHOUSE –
An overview of our services

1. Manufacturing of workwear

It may seem as if the expression “workwear” is relatively modern, originating from the age of industrialization. From time immemorial, however, people have communicated their membership of a particular vocational group with their clothes. Garments such as clerical garments or the habit can thus be counted amongst the oldest workwear in the world. We can find traditional workwear amongst trades people, too. A carpenter’s outfit, for example, does not only have a functional and protective aspect, it also serves to give this vocational group a sense of identity.

Today, workwear is used everywhere: in the bistro, at the building site, in hospital, in the kitchen and in many other areas of life.

Workwear serves to protect us during particular work processes and represents a company’s identity. At the same time, it has to be fashionable, hard-wearing, washable and comfortable.

In the case of particular types of finishing, there are specific wear characteristics of the material: Weather resistance, for example, requires the material to be breathable, hard-wearing material also requires it to be light.

However, often when producing this kind of clothing, sewing problems can occur that are the result of using the wrong needle. Those problems are often detected far too late in the production process. By selecting the right needle and point style, however, such problems can be avoided from the outset.



Source: Bierbaum-Proenen

1.1 Typical sewing problems

For the manufacture of workwear, mostly mixed fabrics such as cotton/polyester in various degrees of fineness are used. The use of different material fineness requires that the sewing machine matches the sewing process. If this is not the case, sewing problems such as the following can arise:

- Skip stitches/Thread breakage
- Uneven seam appearance
- Fabric damage
- Seam puckering

1.2 Quality seams with the right sewing parameters

In order to achieve a virtually faultless production, it is necessary that machine, needle and thread coordinate with the material. Changing one parameter without considering the others can lead to an unattractive seam appearance. In order to avoid that, the modification of one parameter should be followed by checking and if necessary modifying all others.

Needle

2. Selection of the right needle

Choosing the right needle size and point style is one of the most important decisions and requirements for any quality assurance. If the influence of needle and point style on seam quality are not taken into consideration when planning the work process, the result can be thread breakage and damage to the material. The choice of needle always depends on material composition, number of material layers, combination of materials and sewing thread.

2.1 Needle size

Depending on the material, before deciding on a point style, a suitable needle size must be chosen.

The right sewing thread is also a factor not to be missed: The size of the needle eye as well as sewing thread size must be precisely coordinated so that the sewing thread can pass through the needle eye with as little friction as possible. This becomes particularly apparent when considering that every given length of needle thread in the case of a double lockstitch passes the needle eye 25 – 60 times until, in the middle of the material, it interlaces with the bobbin thread. This puts a lot of strain on the sewing thread. When deciding on the right needle size, not only material (thin or thick fabric) but also the type of sewing machine must be considered. Often, heavy machines are used that are not suitable for lighter fabrics. Light fabrics are often densely woven and therefore need thin needles between the sizes of NM 70 and NM 80. Heavy machines, however, require thick needles, which often lead to fabric damage.

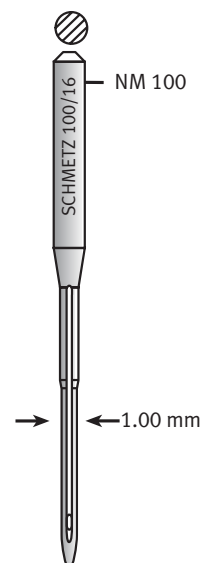

2.2 Point style

Point style is almost as important for a smooth production process as is the right needle size. For the production of workwear, SCHMETZ round and ball points are used.

The normal round point “R” with its pointed conical shape is regarded as the standard point style and has many fields of application. It pierces the weave yarns which creates a very straight seam.

Compared with the “normal” round point “R”, the light ball point “SES” has a hemispherical tip at the end of its point and

thus prevents piercing the weave yarn. As a result, the material is displaced and remains undamaged.

For sewing medium to coarse materials, we recommend the use of needles with a medium ball point “SUK” (especially with thick needles). They have a more pronounced, more rounded point style than the light ball point “SES”, which optimally avoids damage to the weave yarn in the case of twill weave materials.

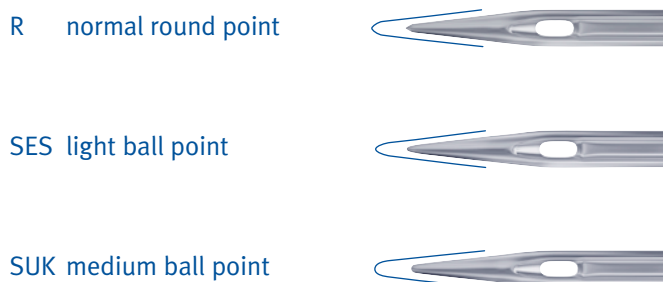

2.3 SERV 7 needle construction

When sewing workwear, seam puckering as well as skip stitches are a common problem. Especially when sewing several layers of materials, much strain is put on the needle.

Skip stitches occur during stitch formation when the thread loop is not caught by the hook/looper, interrupting the interlacing or interlooping of upper and lower thread. Skip stitches significantly impair the run and the strength of the seam and therefore the quality of the end product.

The SCHMETZ SERV 7 version is a special needle that avoids skip stitches and needle breakage. This type of needle comes in various point styles – for the particular requirements of different materials.

The distinctive features of the SERV 7 needles are their specially shaped hump scarf and their extra blade reinforcement. The hump scarf ensures that even in the case of a small or non existing loop, there is enough room between the bottom of the hump scarf and needle thread. The hook/looper point can easily pick up the sewing thread at any time.

The SERV 7 needle’s special stability is particularly beneficial when dealing with several fabric layers.

Because of its blade reinforcement, the needle is particularly stable and is not as easily deflected. Needle breakage is thus kept to a minimum and precise penetration results in a better seam appearance.

In order to achieve very small stitch holes, the size of the SERV 7 needle can be reduced from NM 75 to NM 65, while not impairing the stability of the needle.

SCHMETZ Tip:

Benefit 1: SERV 7 hump scarf produces optimum loop formation and prevents skip stitches.

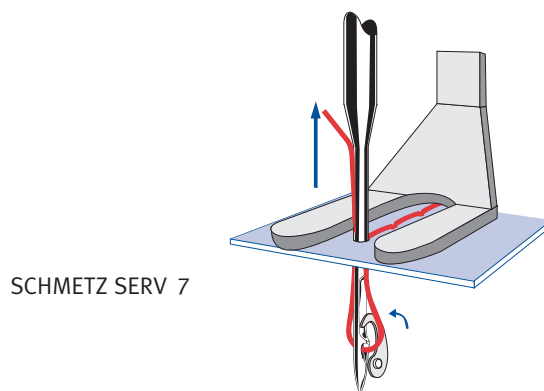

SCHMETZ Tip:

Benefit 2: SERV 7 needle has higher stability increasing needle life.

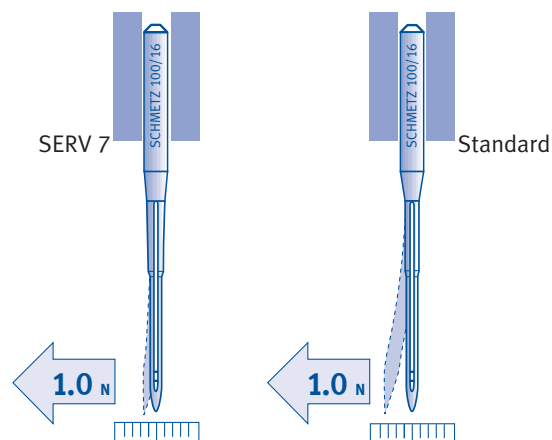

2.4 BLUKOLD needle

Thread breakage that is the result of the sewing machine needle heating up too much when using synthetic sewing threads, is a common problem when sewing workwear. High heat can cause the thread to melt completely or get partially damaged, which in turn leads to thread breakage. Sewing threads made from endless synthetic filaments are particularly unsuitable. If part of the thread breaks or melts, that part pushes against the other undamaged parts and builds up before the needle eye. As a result, the thread can break completely. This often results in melted residue on the needle or the needle eye or groove, which can also cause thread breakage.

When sewing mixed fabrics with more or less synthetic fibers as well as dyed fabrics, problems such as skip stitches and damage to the material can be the result of melted material around the stitch hole. The cause of such difficulties is always that parts of the fabric melt and stick to the needle. As long as such a needle is used, friction between needle and fabric is increased considerably due to the residue sticking to the needle.

In order to reduce or even avoid these problems, we recommend the use of the BLUKOLD special needle.

The BLUKOLD needle has a phosphorated surface coated with Teflon®. This needle surface better prevents or greatly reduces adhesion of residue than, for example, chromium plated needles. It remains clean for a longer period of time – skip stitches and needle breakages happen less often. This ensures a steady sewing process.

During the sewing process, the Teflon® coating of the BLUKOLD needle does not reduce the needle temperature, however, as is often wrongly assumed.

In order to avoid damage to the material, the size of BLUKOLD needles, too, must be matched to material and, if necessary, sewing speed must be reduced.

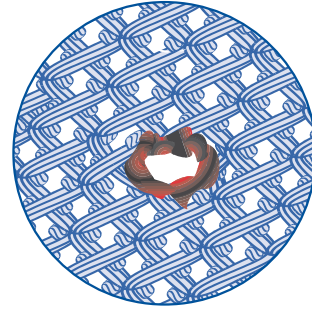

The overheated needle has melted a hole in the sewing material

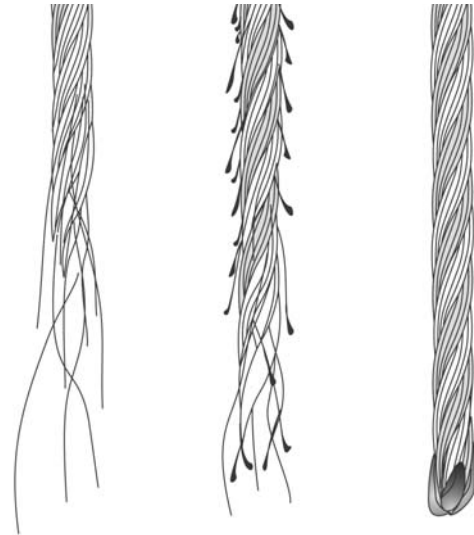

The left thread was broken by mechanical impact (e.g. sharp edges at machine parts).

The problem shown in the middle is most common. Individual fibres of the thread are melting due to the high needle temperature. The thread loses its strength resulting in thread breakage.

The right thread has a bead at its end from melting. This kind of melting only happens at machine stop. The sewing thread is under tension in punctual contact with the hot needle.

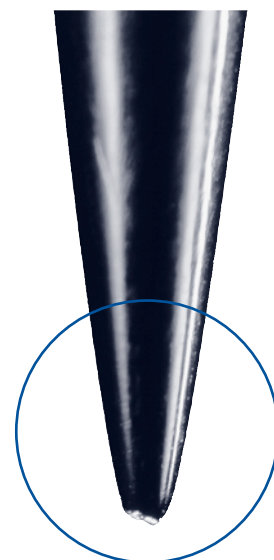

Illustration of a damaged needle point

2.5 Changing of the needle

Even minimal damages to the needle point can cause damage to the material and impair the quality of the end product. Only a perfectly round, smooth ball point guarantees that the needle optimally displaces the weave threads and finds its way through the material layers undamaged. The needle should thus be changed often and at regular intervals.

SCHMETZ Tip:

Check needle tips regularly or replace needles at regular intervals.

Sewing thread

3. Selection of sewing thread and stitch parameters

Workwear should have strong and durable seams that are highly elastic and therefore do not break when stretched. The elasticity of the seam to a high degree depends on stitch type, stitch density and thread tension.

3.1 Composition and size of the sewing thread

For the production of workwear, mostly core spun threads are used.

The use of core spun threads made from 100 % polyester has the advantage of being able to achieve a higher degree of tensile strength and abrasion resistance and therefore a stronger seam. A further plus point is the low degree of shrinkage after washing.

Furthermore, core spun threads with polyester and cotton are used. They are characterized by great thermal resilience and protect the thread if the needle gets too hot.

The size of the sewing thread depends on the type and number of fabric layers.

Light fabrics for example need fine threads No 120, medium fabrics on the other hand need threads such as No 100. For closing seams for disposable clothing, the needle and hook/looper thread are textured sewing threads of size No 160.

Thread type	Core Spun							
	Polyester/Cotton				Polyester/Polyester			
	Yarn size		Needle size		Yarn size		Needle size	
No*	tex*	NM	SIZE	No*	tex*	NM	SIZE	
Medium	40	75	100-120	16-19	40	75	90-110	14-18
	50	60	100-120	16-19	50	60	90-100	14-16
	60	50	100-110	16-18	60/70	50	90-100	14-16
	75	40	90-100	14-16	80	40	70-90	10-14
	80/90	38/33	80-90	12-14	90	38/33	65-80	9-12
Fine	100	30	70-90	10-14	100	30	70-80	10-12
	120	25	70-80	10-12	120	25	70-80	10-12
					140	21	60-70	8-10
	150/160	20/19	65-70	9-10	150/160	20/19	50-60	5-8
	180	17	50-65	5-9	180	17	50-60	5-8

* No = Label number

* tex = Unit of size 1 g/1000 m (e.g. 75 tex = 1000 m yarn weigh 75 g)

3.2 Stitch type

The double chain stitch (401 and 402) is most commonly used with double lap seams. It is also used, however, with regular attaching seams (here usually with securing seams), and also sometimes for sewing pockets, attaching waistbands, hemming etc. Attention must be paid that the chain of the looper thread does not lie on the outer garment surface. This could result in the chain being abraded quickly because of the triple layered looper thread.

Stitch type 401 – double chain stitch (2-thread chain stitch)

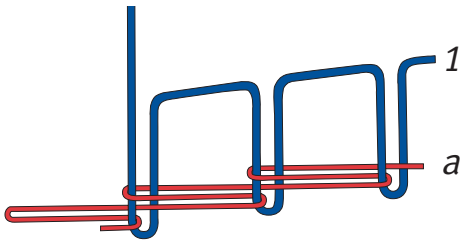

Stitch type 402 – double chain stitch (3-thread chain stitch; 2 needle threads, 1 looper thread)

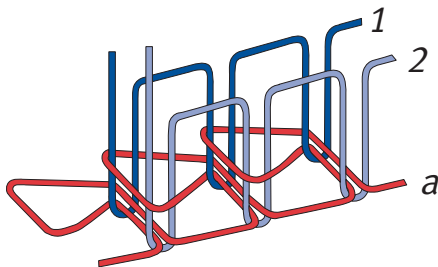

Stitch types such as the double lockstitch (301) and the safety stitch (401.503) are used for long closing seams, as well as side seams and crotch seams.

Stitch type 301 – double lockstitch

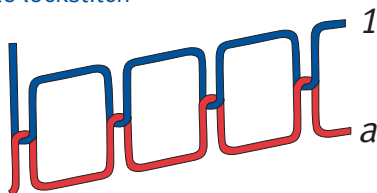

Stitch type 503 – 2-thread overedge chain stitch (edge covering)

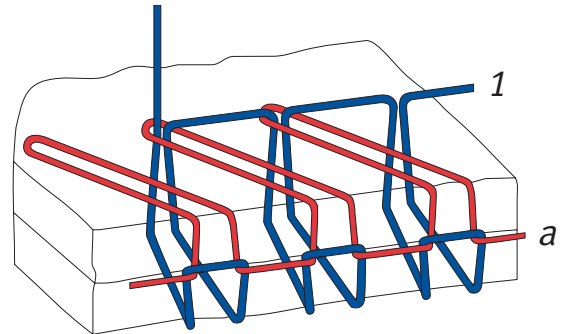

When sewing workwear, the zig-zag stitch is used for e.g. bar-tacking pockets using bar-tackers. This type of stitch is also used for sewing the elastic straps of dungarees for example. The straps are sewn together using a coarse zig-zag stitch to ensure the necessary elasticity.

Stitch type 304 – double lockstitch (zig-zag)

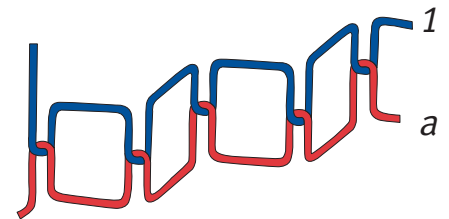

When choosing a stitch type, care must be taken that there is a sufficient amount of thread in the seam. If the amount of thread in the seam is not sufficient then already a small amount of strain could break the seam.

3.3 Stitch density

When choosing stitch density, sewing thread as well as stitch type play an important role.

When using core spun threads No 120, stitch density should be 4 – 5 stitches/cm.

When using core spun threads No 100, stitch density should be 3.5 – 4 stitches/cm.

Stitch type as well as stitch density (stitch/cm) have a significant influence on the elasticity of the seam. The higher the stitch density, the higher the seam elasticity. As a rule, however, stitch density should be no higher than 4 – 5 stitches/cm, otherwise damages and seam puckering/displacement puckering could be the result.

If you do not achieve the desired seam elasticity with the highest stitch density, we recommend that you choose a different stitch type.

3.4 Thread tension

The desired thread tension mainly depends on sewing machine or stitch type, material and sewing thread.

It is assumed that the sewing thread has a certain amount of elasticity of its own. If this is too high, however, undesired puckering can occur. Thread tension should therefore be as low as possible.

Machine

4. Sewing machines for the manufacturing of workwear

In the production of workwear, mostly 1- or 2-needle machines with various bottom and top feed devices are used. They range from high-performance, high-speed sewing machines, automats (for sewing on pockets for example) to various sewing units for closing seams, tucks and trouser pleats.



Flatbed Sewing Machine

Closing and attaching seams, topstitching



Postbed Sewing Machine

Stitching of closing seams on small sections and curved parts



Free-arm Sewing Machine

For stitching closing seams on curved parts

Feed-off-the-arm Double Chain Stitch Machine

(without illustration)

Lap seams (closing seams)

Sewing Automats

(see pict. 1)

Sewing on pockets and buttons, sewing button holes, bar-tacking, sewing pipes and labels

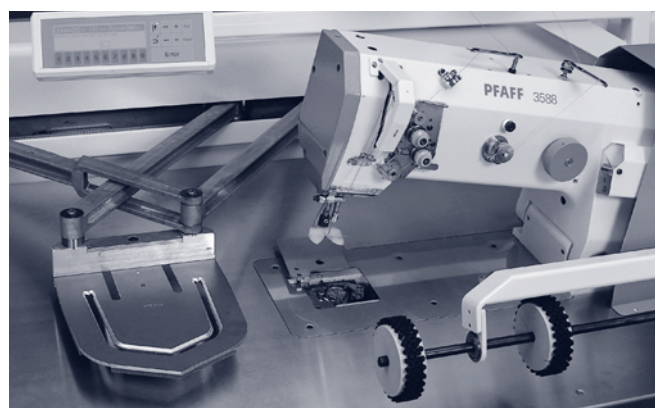

Pict. 1: Automatic Pocket Setter (3588)

Source: Pfaff AG

4.1 Feed

Feed puckering is often the result of a too high presser foot pressure.

In order to avoid feed puckering the feed dog teeth must not be too crude. The aperture of the throat plate should be coordinated with material and needle size.

And finally, as with the needle, attention must be paid that even tiny damage to feed dog, throat plate and hook/looper can lead to material damage.

Depending on the particular machine, sewing machines for workwear are equipped with bottom feed, roller top feed, needle feed and differential bottom or top feed.



Bottom feed with clamp or rail, top feed with clamp or rail

Automatic clamping feed systems

For displacement-free and precise sewing according to predetermined seam pattern



Drop feed

For sewing fine to medium materials without displacement



Drop feed and roller top feed

For sewing feed-critical materials and displacement-free seams



Compound feed

For smooth sewing of material causing particular feed difficulties, useful for topstitching (ensures even stitch lengths, facilitates sewing corners)



Drop feed and walking foot top feed

For sewing fine material or material causing particular feed difficulties; useful for incorporating constant or partial extra width

4.2 Throat plate/Throat plate aperture size

The choice of throat plate is determined by type of feed, needle size as well as additional accessories.

The throat plate aperture size must be coordinated with needle size. If the throat plate aperture is too large there is the danger that the material is pushed into the aperture by the needle; the result can be skip stitches and damage to the material.

Needle size /Throat plate aperture size								
Needle size [NM]	60	65	70	80	90	100	110	120
Throat plate aperture size [mm]	1.00	1.20	1.20	1.40	1.60	1.60	2.00	2.00

Relationship of needle size to throat plate aperture size

4.3 Sewing speed

Sewing speed depends on machine and type of fabric. Machines with a speed of no more than 3,000 – 4,800 stitches/min are used as well as machines with a speed of up to 7,000 stitches/min. Workwear is usually made from mixed fabrics. Therefore, materials with a high synthetic content should not be sewn with too high a sewing speed, which could lead to damage to the material. Sewing speed should be between 3,000 and 4,000 stitches/min.



Source: Bierbaum-Proenen

5. Our advice

You can achieve damage-free quality seams if all the sewing parameters are precisely coordinated with one another.

Material, needle, thread and machine are the key variables. The **SCHMETZ SERVICEHOUSE** offers various service packages:

From recommending the ideal needle for your fabrics to sending out sample needles and providing assistance with special sewing requirements. In addition the **SCHMETZ SERVICEHOUSE** offers competent on-site advice on your production line and training courses for your employees.

**Challenge us –
let us show you our competence!**

Form to copy and fax: + 49 (0) 24 06 / 85-186

Do you have further questions about sewing workwear?
Would you like support in solving your individual sewing problem?
Would you like recommendations on needle selection and sewability of your fabrics in advance of production?
Challenge the SERVICEHOUSE experts and take advantage of our offer.

We will be pleased to send you information on:

Our range of service:

CONSULTING

SAMPLE NEEDLES

Sample needles, tips and information

DOCUMENTED SEWING REPORTS

Sewing reports tailored to match your sewing goods as well as solutions for your complex sewing demands

EXPRESS CONSULTING

Express consulting by phone, fax or e-mail

INFORMATION

SEWING FOCUS

Sewing information for special industries and applications

PRODUCT FOCUS

Product information for special industries and applications

GUIDE TO SEWING TECHNIQUES

Manual for sewing industry

TRAINING/SYMPOSIUM

TRAINING-ON-SITE

Industry specific training including the latest information on needles, threads, machines and applications

SYMPOSIUM

Interdisciplinary knowledge sharing and exchange of expertise for skilled sewing industry staff



Company name
Attention
Position
Address
Postcode/City
Country
Phone
Fax
E-Mail